



3 <sup>3</sup>/<sub>4</sub>''' x 6'''



Cal. 1032/732

### 1. Werkdimensionen

### 1. Dimensions des mouvements

### 1. Movement dimensions

Kaliber	Dimension	Ø Total	Ø Werksitz	Werkhöhe	Höhe Batterie	Höhe Stellwelle	Höhe Werkauflage
Calibre	Dimension	Ø Total	Ø Encageage	Hauteur mouvement	Hauteur pile	Hauteur tige	Hauteur filet
Caliber	Dimension	Ø Total	Ø Case fitting	Movement height	Height of battery	Height of stem	Movement rest
Unit	mm	mm	mm	mm	mm	mm	mm
<b>1032/732</b>	9,00 x 13,20	14,00	13,50	1,95	2,10	0,62	0,20
Stellwellengewinde / Filetage de la tige / Stem thread : Ø 0,70mm					Weg / Chemin / Length of travel 0.30mm		

### 2. Funktionen

### 2. Fonctions

### 2. Functions

Kaliber	Stellwellenpos.	Funktionen
Calibre	Pos. de tige	Fonctions
Caliber	Stem position	Functions
1032/732	1	Normale Position / Position normale / Running position
	2	Zeiger stellen Mise à l'heure Hand setting

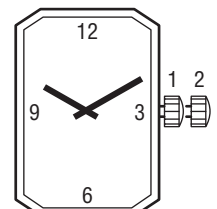

3 3/4 x 6''' 1032/732

3 3/4 x 6''' 1032/732

Plan No.	Bestandteile	Fournitures	Spare Parts
2000.469.G	Werkplatte	Platine	Main plate
2020.118.G.M01	Räderwerkbrücke	Pont rouage	Train w. bridge
3000.142	Stellwelle	Tige	Stem
3001.032	Kupplungstrieb	Pignon coulant	Sliding pinion
3004.128.FI	Zeigerstellrad	Renvoi	Setting wheel
3007.046.CO	Wechselrad	Minuterie	Minute wheel
3015.043	Wippe	Bascule	Yoke
3017.040	Stellhebel	Tirette	Setting lever
3122.051.CO	Kleinbodenrad	Roue moyenne	Third wheel
3147.035.CO	Zwischenrad	Roue intermed.	Intermed. wheel
3305.230.CO	Minutenrohr	Chaussée	Cannon pinion
3600.019	Batterie	Pile	Battery
3601.061.G	Batteriehalter(+)	Bride pile(+)	Battery clamp(+)
3602.015	Batteriekontakt(-)	Bride contact(-)	Battery contact(-)
3603.041	Kunstst.-Zw.-teil	Potence plast.	Set. mech. cover
3603.042	Batt.Isolation	Isolateur pile	Battery insulation
*	Modul	Module	Module
3621.058.RK	Spule	Bobine	Coil
3622.017	Stator	Stator	Stator
**	Spulenschutz	Protection bobine	Coil protection
3715.053.RK	Rotor	Rotor	Rotor
4000.268	Schraube	Vis	Screw
4010.102	Schraube	Vis	Screw
4010.141	Schraube	Vis	Screw
4301.103	Stift für Potence	Pivot potence	Pilar

Cal. 732	Zifferblattseite / Côté cadran / Dial side
Plan No.	Bestandteile
3301.164	Stundenrad
3315.011	Spreizfeder

Batterien / Piles / Batteries

1032/732	Nr. 317 Dim.Ø x H:	SR 516 SW 5,80 x 1,60
----------	-----------------------	--------------------------

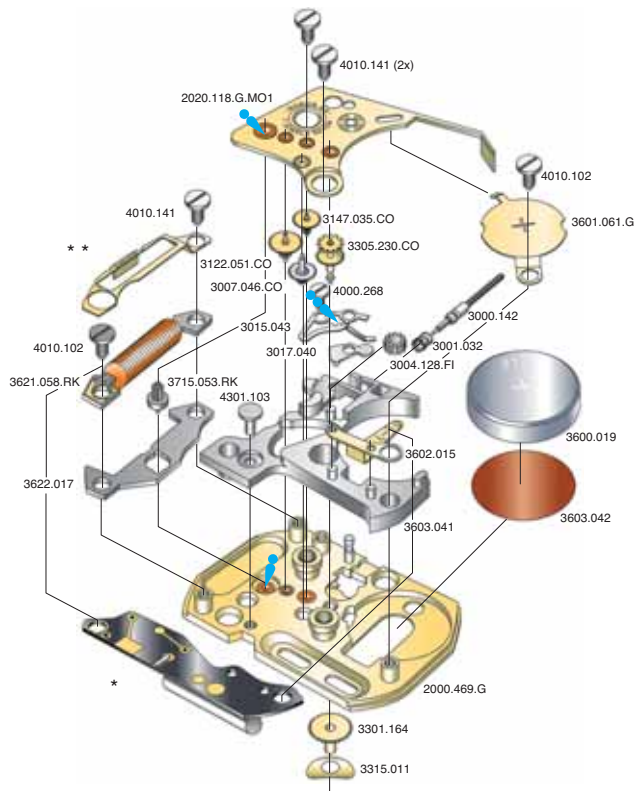

••••• Dünnpflüssiges Oel, z.B. Moebius 9030  
 ••••• Fett, z.B. Moebius, Microgliss D5, Jisma 124

	1032 SWISS MADE	1032 SWISS PARTS	732 SWISS MADE	732 SWISS PARTS
* Modul Module Module	3612.155		3612.057	
** Spulenschutz Protection bobine Coil protection	3651.024.G.M01	3651.024.M02	3651.023.G.M01	3651.023.M02

### 3. Leistungen

### 3. Performances

### 3. Performances

Kaliber Calibre Caliber	Bedingungen Conditions Conditions	Momentaner Gang March instantanée Instantaneous rate	Stromaufnahme Consommation courant Power consumption	Drehmoment Couple utile Torque	Gangreserve Autonomie Autonomy
	Einheit / Unité / Unit Typ.Wert / Valeur / value	Mi (s/month)	I (µA)	T (µNm) min.	A (Monat/mois/month)
1032	1,55 V 23°C Batt./ Pile 11,5 mAh	- 10/+ 20	0,24 < 0,32	15,4	65
732	1,55 V 23°C Batt./ Pile 11,5 mAh	- 10/+ 20	0,28 < 0,38	15,4	56
Magnetfeldabschirmung / Résist. aux champs magn. / Resist. to magnetic fields			18,8 Oe	1500 A/M	Norm 
Betriebstemperatur / Température d'opération / Operating temperature			0–50°C		
Schockresistenz / Résistance aux chocs/ Shock resistance			NIHS 91–10		

### 4. Elektr. Messungen

### 4. Contrôles électriques

### 4. Electrical checking

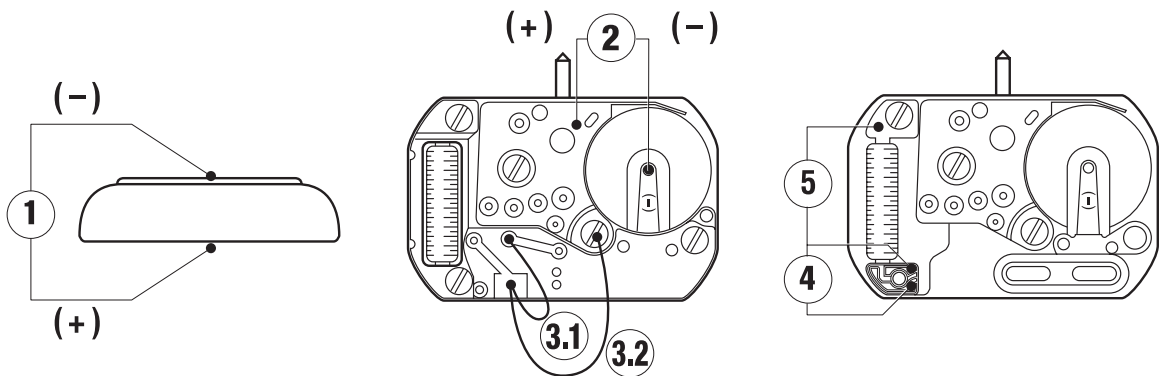

Kaliber Calibre Caliber	Pos. Pos. Pos.	Einheit Unité Unit	Messwerte Valeurs mesurées Measured values	Kontrolle Contrôle Check	Bemerkungen Remarques Remarks	
1032/732	1	V	1,55	Batterie-Spannung Tension de la pile Battery voltage	Batterie herausnehmen und messen Enlever et mesurer la pile Remove battery for measuring	
1032/732	2	µA	0,28 < 0,38 Puls/20 sec., impulsion/20 s., pulse/20 sec. ~ 3,30	Stromverbrauch Consom. de courant Power consumption	Ohne Batterie, mit externer Speisung 1,55 V Sans pile, avec alimentation externe de 1,55 V Without battery, with ext. power supply 1,55 V	
1032/732	2	V	1,35 V	Funktionskontrolle bei Minimalspannung Contrôle de fonctionnement à tension min. Operation with lowest possible voltage	Ohne Batterie, mit externer Speisung unter Kontaktierung von Punkt 3.1 (Acc.) Sans pile, alimentation externe en relayant le point 3.1 (Acc.) Without battery, with external power supply by contacting point 3.1 (Acc.)	
1032/732	3.1	Hz	32 Hz	Motorimpuls beschleunigt Impulsions de moteur accélérées Accelerated motor pulses	Mit Batterie oder externer Speisung 1,55V Avec pile ou alimentation externe de 1,55 V With battery or ext. power supply of 1,55V	
1032/732	3.2	Hz	0	Motorimpuls unterbrochen Impulsions de moteur interrompues Interrupted motor pulses	Mit Batterie oder externer Speisung 1,55V Avec pile ou alimentation externe de 1,55 V With battery or ext. power supply of 1,55V	
1032/732	4	K	1,80–1,95	Spulenwiderstand Résistance de la bobine Coil resistance	Ohne Batterie Sans pile Without battery	
1032/732	4	K	∞	Spulenisolation Isolation de la bobine Coil insulation	Ohne Batterie Sans pile Without battery	
1032/732		Sek. / Monat sec. / mois sec. / month		- 10/+ 20	Induktivsonde 60 Sekunden Senseur inductif 60 secondes Inductive sensor 60 seconds	Mit Batterie Avec pile With battery

## 5. Zeigerwerk

## 5. Aiguillage

## 5. Dial-train

Zeigerwerk		Einzelteil-Höhe	mm	Höhe ab Zifferblattauflage	mm	Ø Zeigeranpassung	mm	Zifferblattdicke	mm
Aiguillage		Hauteur de la pièce ind.	mm	Déplacement platine	mm	Ø Ajustement des aiguilles	mm	Epaisseur du cadran	mm
Height of dial train		Height of individ. piece	mm	Height from base	mm	Ø Adjustment of hands	mm	Dial thickness	mm
1032	732	A	B	E	F	H	I		
0	1	2,77	0,83	0,94	0,60	0,80	0,40	0,30	
1	2	2,97	1,03	1,14	0,80	0,80	0,40	0,50	
2	3	3,27	1,33	1,44	1,10	0,80	0,40	0,80	
3	4	3,67	1,73	1,84	1,50	0,80	0,40	1,20	

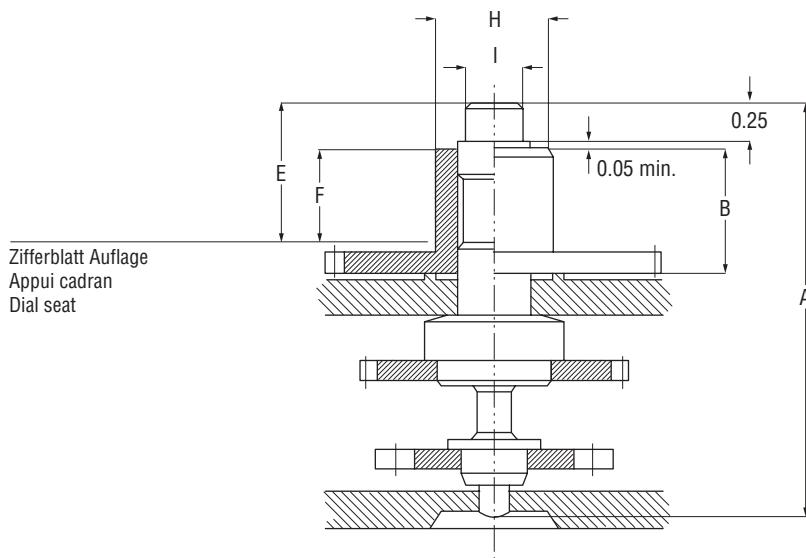

Für Einzelheiten verlangen Sie bitte die entsprechenden Zeigerwerkpläne!  
 Pour plus de détails demandez nos plans d'aiguillage!  
 For more detailed information please ask for the corresponding hand plans!

## 6. Einschalen / Werkzeuge

## 6. Emboîtement / outils

## 6. Casing / tools

Nr. H 1032.1A



### Zeigersetzen

Maximale Aufpresskraft:

– Stunden und Minutenzeiger: max. 40N

Beim Zeigersetzen muss das Werk abgestützt werden.

### Poser les aiguilles

Force de chassage maximale:

– Aiguilles des heure et des minutes: max. 40N

Lors de la pose d'aiguilles, le mouvement doit être soutenu.

### Hand setting

Maximal force:

– Hour and minute hands: max. 40N

The movement needs to be supported for hand setting.

Nr. H 1032.1T



### Stellwelle entfernen

Beim Entfernen der Stellwelle muss sich die Stellwelle in Position 1 (gedrückt) befinden, bevor auf den Winkelhebel gedrückt wird.

### Enlever la tige

En enlevant la tige, la tige doit se trouver en position 1 (poussée), avant de pousser sur la tirette.

### Stem removal

For removal of the stem, the stem must be pushed into position 1 (pressed in) prior to apply pressure to the setting lever.

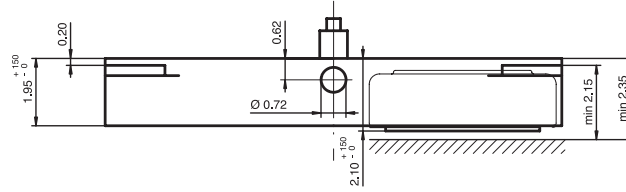

Seite Gehäuseboden  
Côté fond de boîte  
Case back side

Zifferblattseite  
Côté cadran  
Dial side

Zifferblattfüsse  
Pieds de cadran  
Dial feet

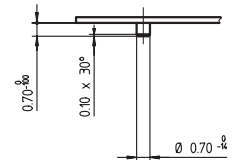
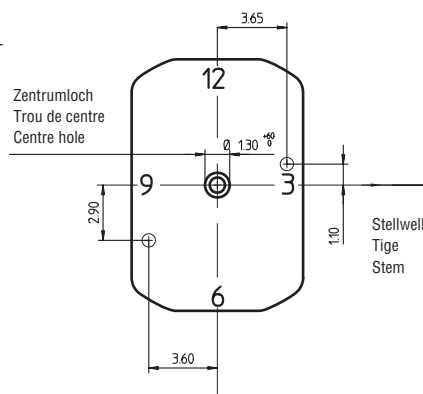
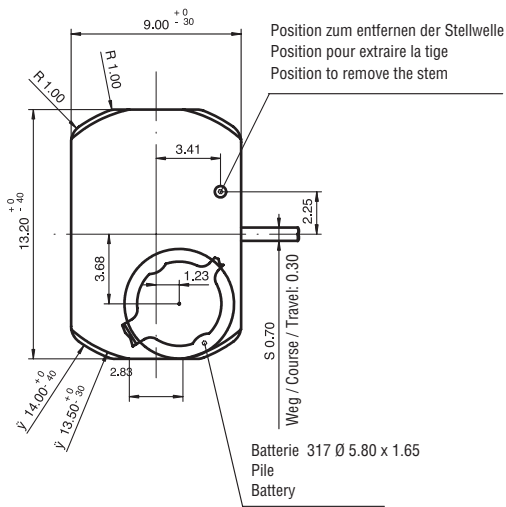

Sicherheit zwischen Minutenzeiger und Glas	min. 0,30 mm
Sécurité entre l'aiguille des minutes et le verre	min. 0,30 mm
Security between minute hand and glass	min. 0,30 mm

Das Zifferblatt muss durch die Schale gehalten werden.  
Le cadran doit être tenu par la boîte.  
The dial must be hold by the case.

Ajustement aiguille des heures  
Stundenzeigerpassung  
Hour hand fitting

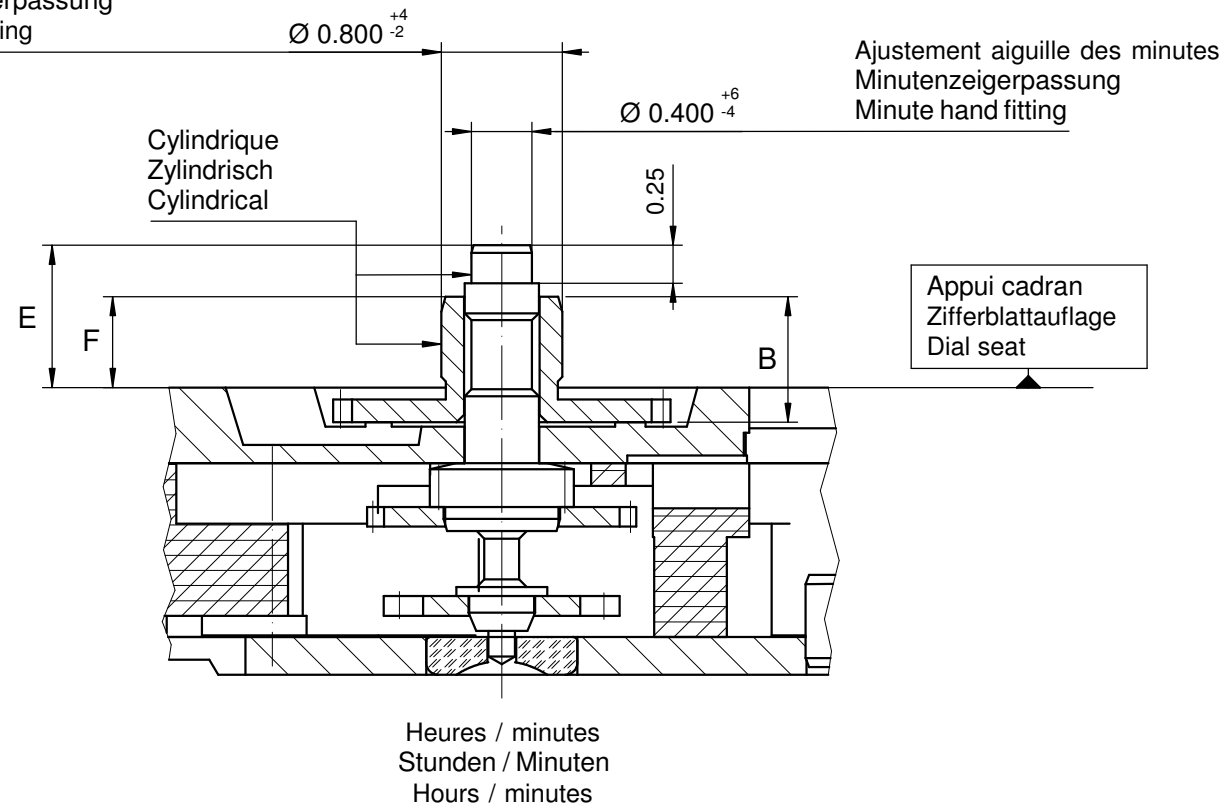

Ajustement aiguille des minutes  
Minutenzeigerpassung  
Minute hand fitting

Aiguillage no. Zeigerwerkhöhe Nr. Hand fitting height No	Dépassement Höhe über Zifferblattaufgabe Height over dial seat			Longueur Länge Length		Epaisseur max. (peinture comprise) Max. Dicke (inkl. Farbe) Max. thickness (paint included)			
	Chaussée Minutenrohr Cannon-pinion	Roue des heures Stundenrad Hour wheel		Roue des heures Stundenrad Hour wheel		Cadran Zifferblatt Dial		Aiguilles Zeiger Hands	
						Sous l'aiguille des minutes Unter Minutenzeiger Under minute hand	Sous l'aiguille des heures Unter Stundenzeiger Under hour hand		
E	F		B						
0	0.94	0.60		0.83		0.50	0.30		0.15
1	1.14	0.80		1.03		0.70	0.50		0.15
2	1.44	1.10		1.33		1.00	0.80		0.15
3	1.84	1.50		1.73		1.40	1.20		0.15

	Aig. des minutes Minutenzeiger Minute hand	Aig. des heures Stundenzeiger Hour hand	Lors de la pose d'aiguilles, le mouvement doit être soutenu. Beim Zeigersetzen muss das Werk abgestützt werden. The movement needs to be supported for hand setting.
mg max.	30	30	Masse / Masse / Weight *
µNm max.	0.12	0.12	Balourd / Unwucht / Unbalance *
gmm <sup>2</sup> max.	-	-	Inertie / Massenträgheit / Inertia *
N max.	40	40	Force de chassage / Aufpresskraft / Force

Sous réserve de toutes modifications

Aenderungen vorbehalten

All modifications reserved

Aiguillages  
Zeigerwerkhöhen  
Hand fitting heights

3 3/4 x 6'''

RONDA

1032

Issued	02 Feb 2005	fl
Modified	18 Feb 2011 ÄA 10340	ps
Released	Yes	
Tolerance	µm	
Scale	20 : 1 (A3H)	
Sous réserve de modifications Aenderungen vorbehalten Modifications reserved		
No.	3316.093	04

\* En cas de données différentes, veuillez contacter le service après-vente

\* Bei abweichenden Werten, bitte technischen Kundendienst anfragen

\* In case of different values, please contact the customer service